

---

# SSR Protection

## IT Inc. Meeting with ERCOT

March 12, 2010  
Austin TX





Instrumentation Technology

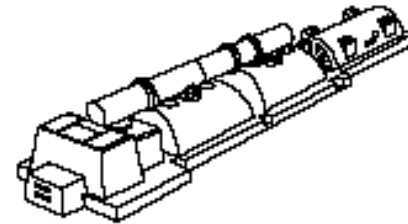

## Colin E. J. Bowler

President

Instrumentation Technology Inc.  
108 Clear Sky Ct.  
Cary, NC 27513

SSR Protection and Mitigation Systems  
Equipment Surveillance Monitoring  
Power System Dynamic Analysis  
Custom Instrumentation  
DSP Control Systems

(919)-380-1039 Voice  
(919)-656-5853 Cell  
(919)-460-1597 Fax  
[cbowler@inst-tech.com](mailto:cbowler@inst-tech.com)

# Presentation Order

- IT Inc. Resources
- Application Values
- The Offering
- Qualification
- Certification
- Questions



# Instrumentation Technology Inc. Resources

- Formed in 1999
  - SSR Protection Systems (22 turbine-generator systems)
  - System Consulting Services - ESKOM, PG&E, XCEL, SCE, Pacificorp
- Company Resources
  - Colin Bowler IT, SSR, Power Systems Eng., Embedded Systems Design
  - John Tarnawski Instrumentation, Embedded Systems
  - Duncan Walker Consultant - Rotor Dynamics
  - Dennis Ulery PE Consultant - Stress Analysis/Rotor Dynamics
  - Mike Brown PhD U Belfast Mathematician, Controls Engineering
  - Consulting Partner for ABB, KEMA
- Technical resources
  - Matlab / Simulink
  - Load Flow & Stability
  - EMTP System simulation
  - SSR Frequency Scan & Small Signal Stability Analysis
  - Torsional model development, Model parameter identification
  - Torsional fatigue



# Application Values

- Turbine-Generator System Interaction Concerns
  - System faults and Transmission Operation (HSR)
  - Controls interaction (HVDC, FACTS Transmission Devices)
  - SSR interaction (Series capacitor compensated transmission)
  - Steel Mill Drives and Arc furnace interactions
- Application Value
  - SSR protection
    - Torsional stability
    - Shaft Fatigue
  - SSR Mitigation
    - Damping Control
  - Remaining Life Monitoring
    - Electromagnetic response component
      - Crack propagation
        - Key-ways, Wheel disks, Blade roots
    - Combine torsional lateral monitoring
      - Torsion driven crack propagation
        - Leading to lateral vibration
  - Feedback on System Design
    - Opportunity to make changes affecting reliability

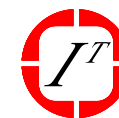

# DMF SSR Protection

- Torsional Response Protection
  - Very Fast Reliable Detection and Protection
    - Prevents severe fatigue damage
  - Proven secure and dependable
    - Secure – No False Trips
    - Dependable – Always trips when required
- Torsional Response Monitoring
  - Capture response data and its precursors
    - Generator Voltage and Current
    - Electromagnetic torque
    - Actual response
    - Predicts stress and fatigue



# DMF SSR Protection - Hardware

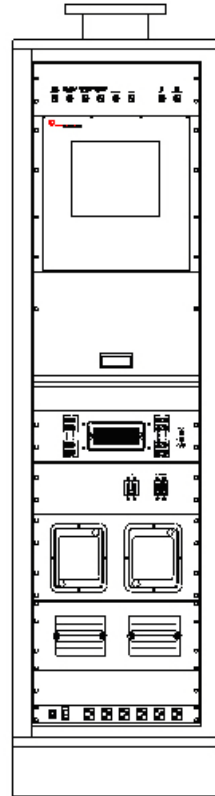

- DMF module
  - cPCI DSP system
    - Busmaster -Windows independent
  - Pentium CPU
    - Windows 2K
  - GPS
- Printer
- Keyboard mouse
- FT1 Simulator Signal Injection (e.g. OMICRON)
  - 3 phase V & I
  - Front and Rear velocity (12 sensors)
- Aux relay
  - Multi contact
  - 1 Cycle trip



# DMF System Key Features

- Real-Time response simulation
  - Two ADSP21062 Sharc based Floating point DSP's
    - 120 MFLOP performance
  - Extension capability with four ADSP21160 DSP's
    - 1920 MFLOPS performance
    - Higher order super-synchronous response monitoring & protection
- 32 Channel digital oscillograph
  - Simultaneous sampling
  - 7200 Hz per channel sample rate
  - 32 additional computed channels
  - GPS event-time synchronization
- Computing
  - Generator electromagnetic torque
  - Rotor velocity all mass locations
  - Shaft torque & fatigue



# DMF Module

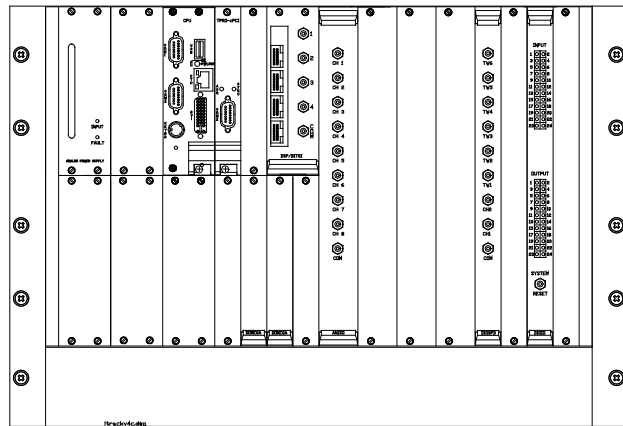
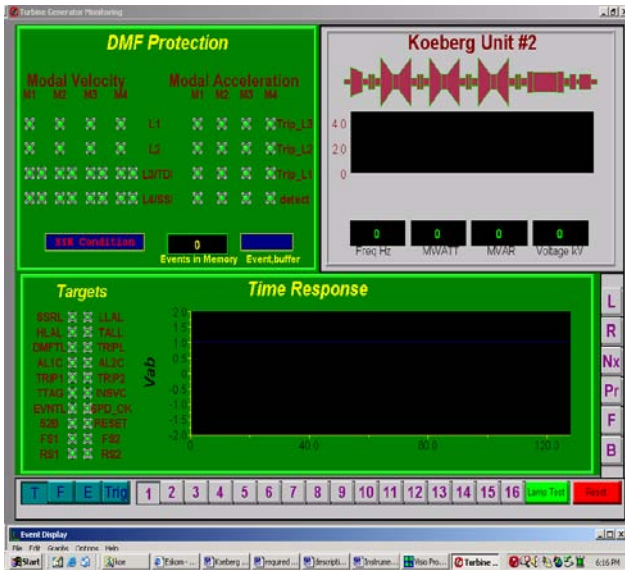

- Real Time Window
  - Latched protection targets
  - Shaft torque bar chart
  - Oscillograph
    - Channel selection
    - Auto & Manual trigger
    - FFT
- Hardware module
  - Euro style cPCI CPU/Backplane
  - Windows independent
    - Bus master data acquisition
    - DSP based protection
    - Hardware targets
    - Trip and Alarm output
  - Windows dependent
    - Data storage
    - Data viewing
    - Data Communication



# Oscillograph Function

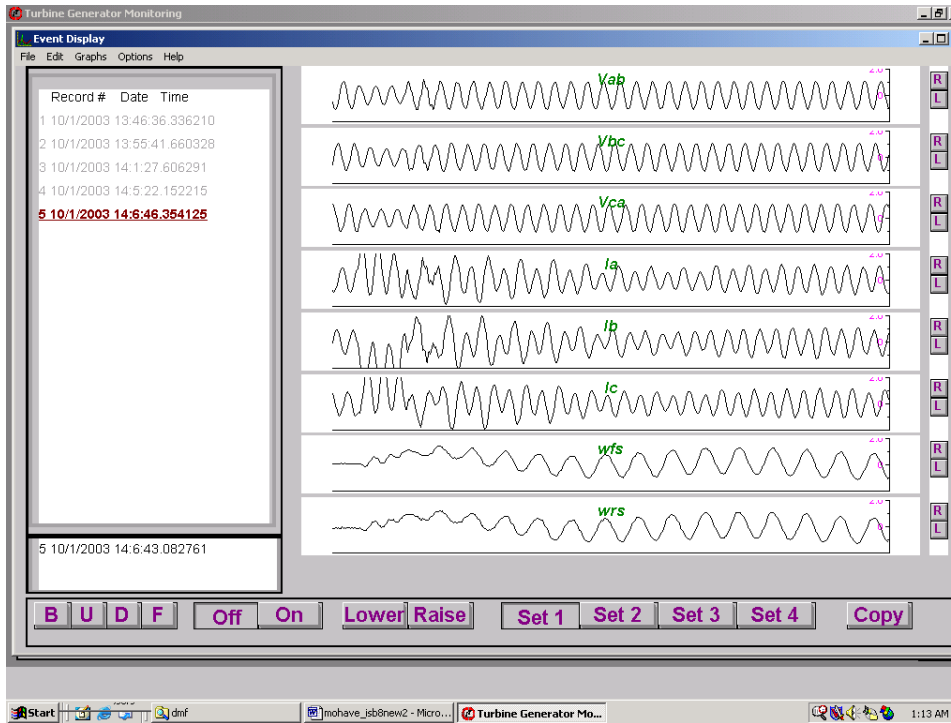

- Event view and selection
  - GPS Time-stamp
  - Event number
- Channel group selection
- Time scale
  - Compression
  - Scroll event
- Channel gain control
- Window functions
  - File operations
  - Setting operations
  - Copy Conversion
    - Single event DMF format
    - COMTRADE format
    - EXCEL Format

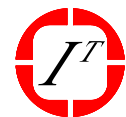

# DMF Torsional Protection

- Protection Philosophy
  - TG transduces it own response
- SMF Function
  - Filtered Single Mode frequency response
    - Velocity based time delay trip
    - Stability detect trip
- DMF Function
  - Observer based instantaneous modal frequency response
    - Velocity permissive
      - Acceleration based time delay trip
      - Trips before reaching resonant peak

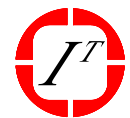
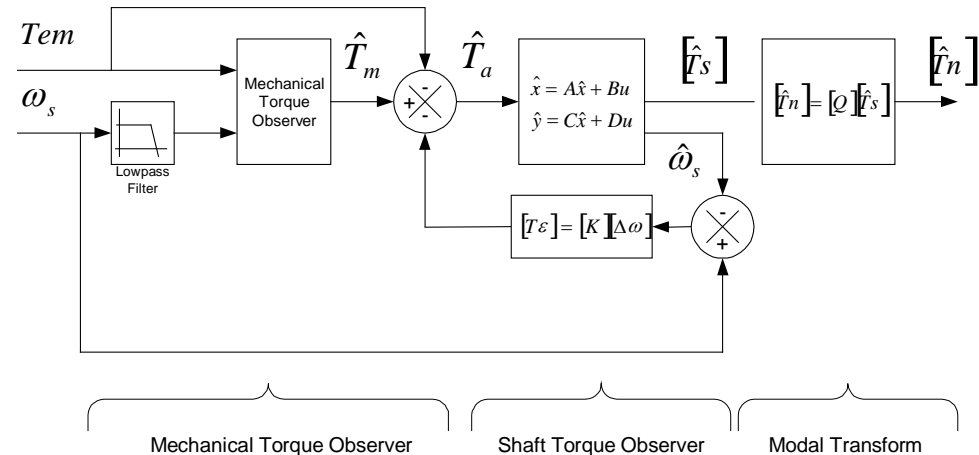
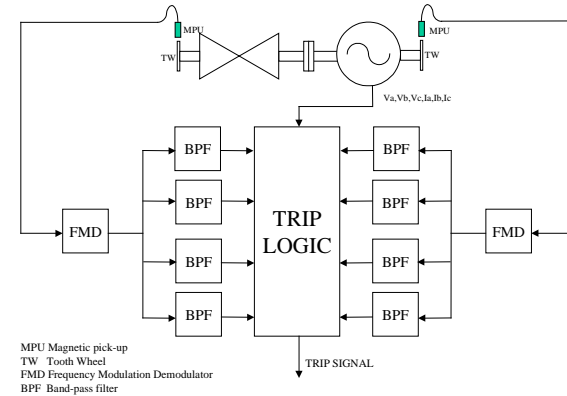

# DMF Torsional Protection

- Observer based real-time process
  - Measure applied torques & velocity
  - Predict torsional response & shaft fatigue
  - Acceleration feedback to converge calculated and measured instantaneous response at key locations
  - Current Process aimed at subsynchronous torsional protection from SSR induced resonant response.
  - Adaptable to any dynamic process
    - Especially useful where response variables are inaccessible
    - When dynamic process is reasonably linear
  - Opportunity for understanding life-time issues
    - Externalities such as system disturbances
    - Internal stimuli such as engine-order harmonic forces
    - Fatigue processes



# Requirements

- Reasonably accurate torsional model
  - Observer accommodates model errors
  - Accounts for damping variability - all sources
- Appropriate response measurements
  - Measurement locations must have observability of all modeled modes of vibration and reject all others
- Understood fatigue regime
  - Time to crack initiation model
  - Crack propagation model



# Generating Accurate Models

- Build physical model from geometry
  - Account for non uniform stress distribution
    - Form factor variation of stiffness
      - Elliptical & Cruciform generator rotor section
        - Wedge Locking Stiffening
      - Abrupt changes in rotor diameter
      - Shrink-fit stiffness adjustments
- Calibrate physical model by test and event monitoring
  - Model parameter identification
    - Applied Electromagnetic Torque, Rotor velocity, Coupling velocity
  - Sweep test for mode-shape and frequency
    - Adjustments for G-field effect on blade vane stiffness
  - Rated-speed low-voltage short circuit test for final calibration
    - Micro-version of actual events
      - Balanced and unbalanced fault



# Typical Modeling

- Gas Turbine Example
  - 140 mass reduced to 9 mass
  - Max frequency 304 Hz
  - TW at each end of Generator

- Steam turbine example
  - 340 mass reduced to 22 mass
  - Max frequency 160 Hz
  - TW at each end of TG
  - L-0 Blade modes required

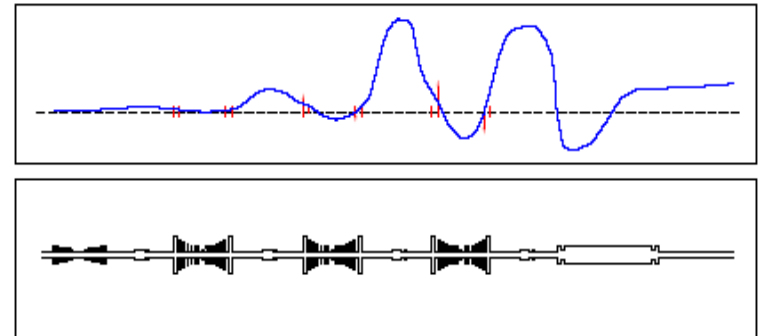
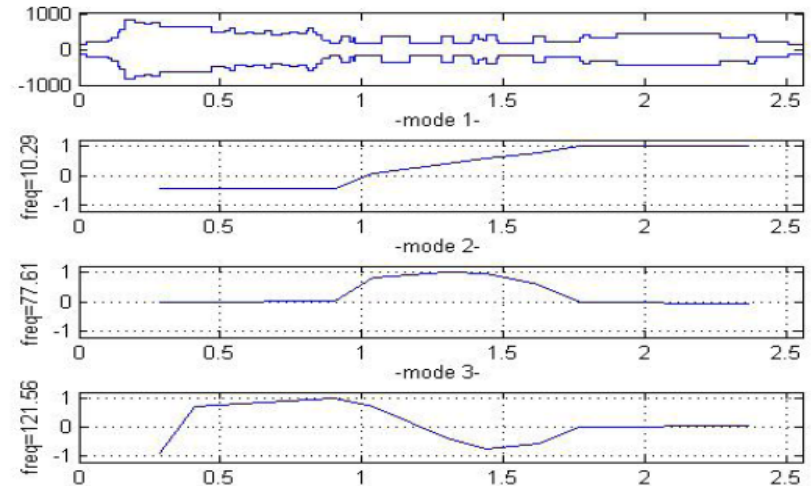

# DMF Qualification

- Qualification by Real Time Event Simulation – Mohave Example
- Stability Evaluation
  - Model system for operating range calculating torsional damping contours
  - Variables
    - Units in operation
    - Levels of line series compensation
    - Line outages
  - Establish range of conditions suitable for operation
- Time response and fatigue

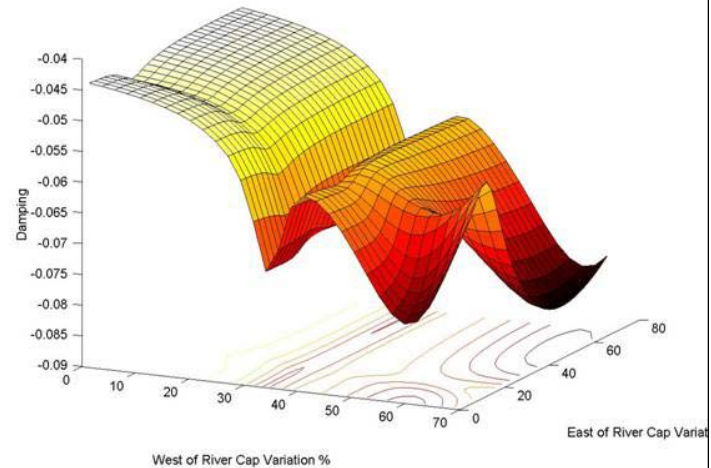
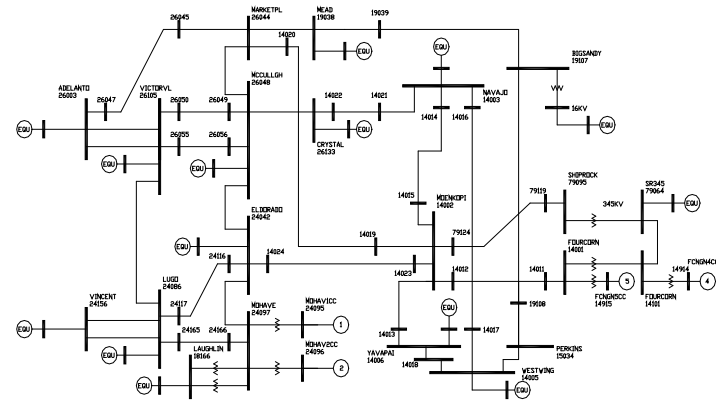

# DMF Qualification

- Time response evaluation
  - EMTP simulation of full range of cases
    - Fault type
    - Fault timing
    - Fault location
    - System configuration
  - EMTP to COMTRADE event file generation
  - Real-time secondary signal playback to DMF
    - DOBLE/OMICRON System Simulator
    - IT tooth-wheel simulator
    - Inject signals via FT1 switch
  - Compare trip actual with trip requirement from simulation
  - Evaluate all scenarios
  - Evaluate security and dependability of trip
  - DMF Scored 100%
    - 0% False trips
    - 100% Dependable trips

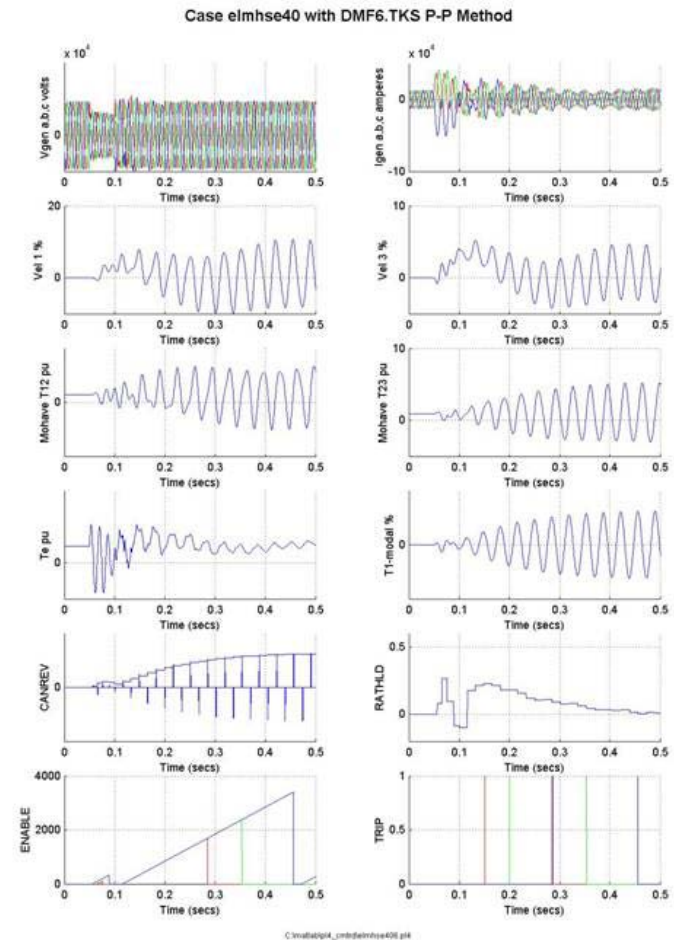

Dependable

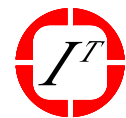

# DMF IEC Certification

## Statement of Compliance

*Manufacturer:* Instrumentation Technology Inc.  
108 Clear Sky Ct.  
Cary, NC 27513  
919-380-1039

*Requester / Applicant:* Colin Bowler  
*Name of Equipment:* DMF Relay  
Model: SSR Relay Torsional Protection Device

*Type of Equipment:* Industrial, Scientific, or Medical (ISM)  
*Class of Equipment:* Class A

*Application of Regulations:* EMC Directive 89/336/EEC  
*Test Dates:* 29 November 2004 to 3 December 2004

*Guidance Documents:*

Emissions: EN61000-6-4:2001  
Immunity: EN61000-6-2:2001

*Test Methods:*

Emissions: EN55011:1998+A1:1999+A2:2002, EN61000-3-2:2000, EN61000-3-3:1995+A1:2001  
Immunity: EN61000-4-2:1995+A1:1998+A2:2001, EN61000-4-3:2002, IEC 61000-4-4:1995+A1:2000+A2:2001, EN61000-4-5:1995+A1:1996, EN61000-4-6:1996+A1:2001, EN61000-4-8:1995, IEC 61000-4-11:2001

The electromagnetic compatibility test and documented data described in this report has been performed and recorded by TUV Rheinland of North America, in accordance with the standards and procedures listed herein. As the responsible authorized agent of the EMC laboratory, I hereby declare that a sample of one, of the equipment described above, has been shown to be compliant with the EMC requirements of the stated regulations and standards based on these results. If any special accessories and/or modifications were required for compliance, they are listed in the Executive Summary of this report.

This report must not be used to claim product endorsement by NVLAP or any agency of the U.S. Government. This report contains data that are not covered by NVLAP accreditation. This report shall not be reproduced except in full, without the written authorization of the laboratory.



NVLAP Signatory

15 February 2005

Date



# Certification

## 1.3 Summary of Test Results

Table 1 - Summary of Test Results

Emission	Test Method(s)	Test Parameters	Result
Radiated Emissions	47 CFR 15, EN55011:1998+A1: 1999+A2:2002, ANSI C63.4:2003	30 MHz to 1000 MHz, Class A	compliant
Conducted Emissions	47 CFR 15, EN55011:1998+A1: 1999+A2:2002, ANSI C63.4:2003	150 kHz to 30 MHz, Class A	Not Required
Harmonic Currents	EN61000-3-2:2000, EN61000-3-3:1995+A1:2001		Not Required

Table 2 - Summary of Immunity Test Results

Disturbance	Test Method	Test Parameters	Result
Electrostatic Discharge	EN61000-4-2:1995+A1:1998+A2:2001	Air: +/- 8 kV Contact: +/- 4 kV	compliant
Radiated Immunity	EN61000-4-3:2002	3 V/m, 80 MHz to 1000 MHz 80% AM Modulation	compliant
Electrical Fast Transient/Burst	IEC 61000-4-4:1995+A1:2000+A2:2001	AC Lines: +/- 1.0 kV DC Lines: +/- 0.5 kV I/O Lines: +/- 0.5 kV	compliant
Lightning Surge	EN61000-4-5:1995+A1:1996	(L-L): +/- 1.0 kV (L-G): +/- 2.0 kV (L-G): +/- 0.5 kV (L-G): +/- 1.0 kV	compliant
Conducted Disturbances	EN61000-4-6:1996+A1:2001	3 V(rms), 150 kHz to 80 MHz 80% AM Modulation	compliant
Power Frequency Magnetic Field	EN61000-4-8:1995	1 A/m, 50 Hz	Not Required
Voltage Dips, Variations, and Short Interruptions	IEC 61000-4-11:2001	>95% for 0.5 periods (dips) -30% for 25 periods >95% for 250 periods (interruptions)	Not Required

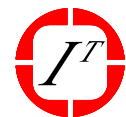

# Certification



Figure 5 - Radiated Emissions Test Setup (Chamber - Front)

TUV Rheinland of North America  
762 Park Ave., Youngsville, NC 27596  
Tel: (919) 554-3668, Fax: (919) 554-3642

Radiated Immunity

### 5.2.3 Photos

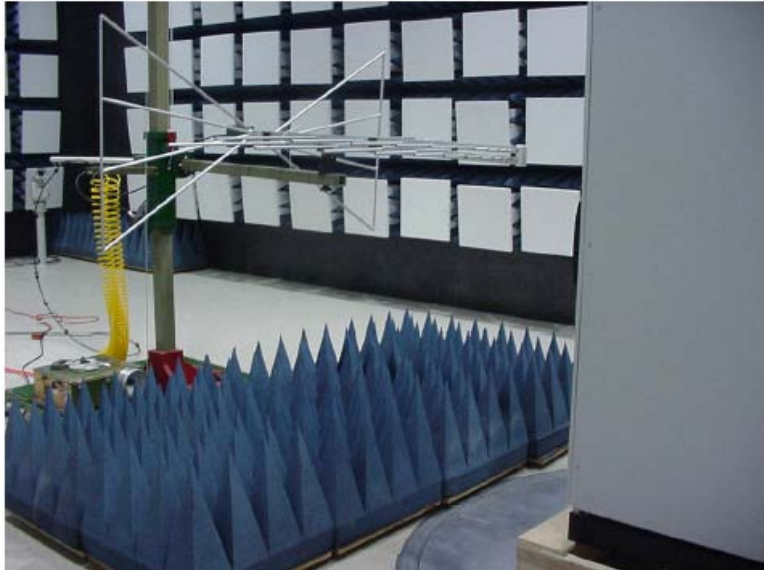

Figure 13 - Radiated Immunity Test Setup (Front)



# Certification

## 6 Test Equipment Use List

Equipment	Manufacturer	Model #	Serial/Inst #	Last Cal dd/mm/yy	Next Cal dd/mm/yy
<b>SOP 1 - Radiated Emissions (5 Meter Chamber)</b>					
Ant. Biconical	EMCO	3110B	3367	4-Feb-04	4-Feb-05
Ant. Log Periodic	AH Systems	SAS-516	133	19-Jan-04	19-Jan-05
Cable, Coax	Andrew	FSJ1-50A	030	15-Jan-04	15-Jan-05
Cable, Coax	Andrew	FSJ1-50A	045	15-Jan-04	15-Jan-05
Chamber, Semi-Anechoic	Braden Shielding	5 meter	A67631	27-Jan-04	27-Jan-05
Data Table, EMCWin	TUV Rheinland	EMCWin.dll	002	6-Jan-02	6-Jan-06
Spectrum Analyzer	Anilout Tec.	E7405A	US39440161	11-Aug-04	11-Aug-05

<b>SOP 3 - Electrostatic Discharge Immunity</b>					
ESD Generator & Tip #1	KeyTek	MZ-15/EC & TPC-2	0011261/0011266	8-Aug-04	8-Aug-05

<b>SOP 4 - Radiated Immunity (5 Meter Chamber)</b>					
Amplifier	IFI	CMX-5001	498-0595	CNR II	SOP 4
Ant. Biconi. Log	EMCO	3143	1138	CNR II	SOP 4
Cable, Coax	Andrew	FSJ1-50A	042	15-Jan-04	15-Jan-05
Cable, Coax	Andrew	FSJ1-50A	045	15-Jan-04	15-Jan-05
Chamber, Semi-Anechoic	Braden Shielding	5 meter	A67631	27-Jan-04	27-Jan-05
Data Table, 30V, Hor.	TUV Rheinland	(30)30V_H.Dat	001	24-Apr-04	24-Apr-05
Data Table, 30V, Ver.	TUV Rheinland	(30)30V_V.Dat	001	24-Apr-04	24-Apr-05
Generator, Signal	Rhode & Schwarz	SMY-01	837396/013	7-Aug-04	7-Aug-05
RFI (5m) Test System	TUV Rheinland	5 Meter		CNR III	CNR III

<b>SOP 5 - Electrical Fast Transient/Burst Immunity</b>					
Clamp, Capacitive Coupling	KeyTek	CCL-4/S	9511290	CNR I	SOP 5
ECAT Control Center	KeyTek	E103	9511349	CNR II	SOP 5, 6
ECAT EFT 4.4kV Module	KeyTek	E411	9511286	8-Aug-04	8-Aug-05
ECAT EFT Surge Coupler	KeyTek	E4551	9511211	8-Aug-04	8-Aug-05
ECAT EFT Surge Module	KeyTek	E501A	9801213	8-Aug-04	8-Aug-05

<b>SOP 6 - Lightning Surge Immunity</b>					
ECAT Control Center	KeyTek	E103	9511349	CNR II	SOP 5, 6
ECAT EFT 4.4kV Module	KeyTek	E411	9511286	8-Aug-04	8-Aug-05
ECAT EFT Surge Coupler	KeyTek	E4551	9511211	8-Aug-04	8-Aug-05
ECAT EFT Surge Module	KeyTek	E508	0010399	11-Aug-04	11-Aug-05

<b>SOP 7 - Conducted Immunity</b>					
Amplifier	IFI	M75	C196-1199	CNR II	SOP 7
Attenuator, High Power	Wamschel	WA45-6-34	4005	CNR II	SOP 7
Cable, Coax	Belden	Mil C17	007	CNR II	SOP 7
Cable, Coax	Belden	RG-223	100	CNR II	SOP 7
CDN, M2	Fischer	FCC-801-M2-25	9803	CNR II	SOP 7
Clamp, EM Injection	Fischer	F-2031-23mm	53	CNR II	SOP 7
Data Table, 10V, M2	TUV Rheinland	CALSG10VM2.Dat	001	19-May-04	19-May-05
Data Table, 10V, EM	TUV Rheinland	CALSG10VEM.Dat	001	19-May-04	19-May-05
Generator, Signal	Hewlett Packard	8648B	3426A00572	7-Aug-04	7-Aug-05
RFCI Test System	TUV Rheinland			CNR III	CNR III

<b>General Laboratory Equipment</b>					
Meter, Multi	Floko	79-3	69200606	6-Aug-04	6-Aug-05
Meter, Temp/Humid/Barom	Fisher	02-400	01	13-Aug-04	13-Aug-05
Power Supply, DC	Sorensen	DCS55-55	0103B1286	CNR II	CNR II

\* Calibration of equipment past due for re-calibration will be performed expeditiously. If any equipment is found to be out of tolerance at that time, affected customers will be notified accordingly.

